



Siempelkamp

Maschinen- und Anlagenbau

Metalforming Presses



www.siempelkamp.com

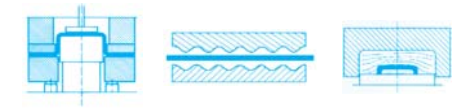

2

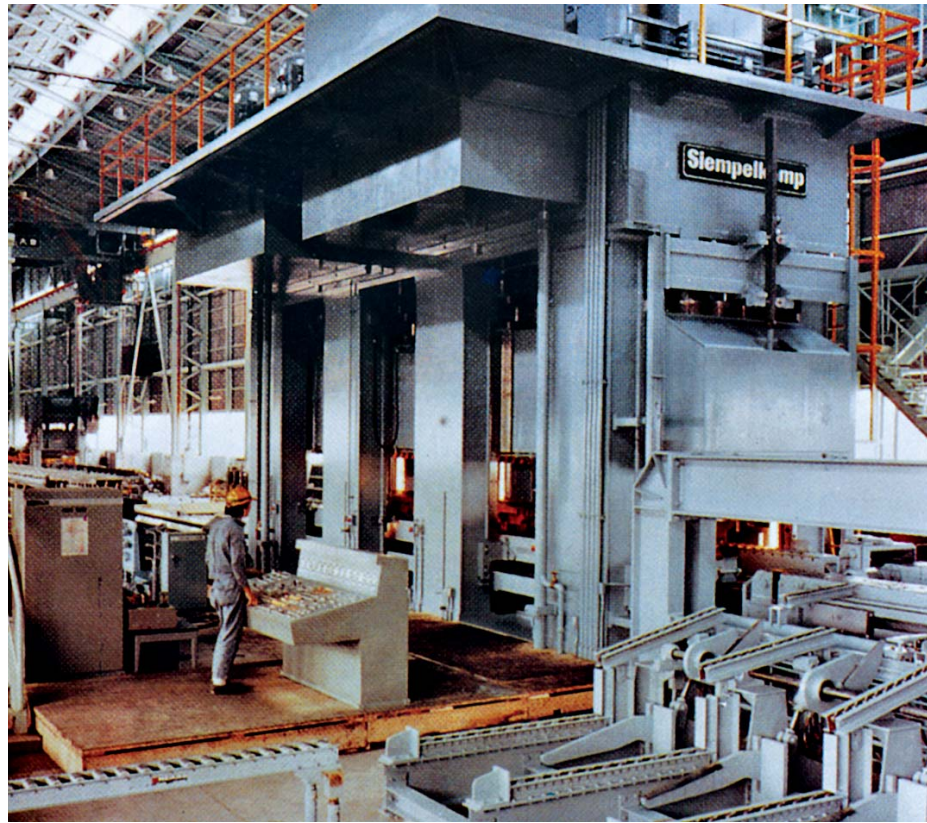

Side member draw press, 50 MN



Side members

Side Member Draw Press

Single-Frame Design
 For blanking and drawing of side members for trucks
 These presses can be equipped with product handling systems and equipment for quick tool change

45 MN deep draw press



Axle Housing Draw Press

Rear axle housings



Heat exchanger plate press line, 150 MN



Typical products

Heat Exchanger Plate Press

For the manufacture of heat exchanger plates and large sheet metal components made of stainless and alloy steels, titanium alloys, etc.
 With: • sheet handling systems
 • equipment for quick tool change

Rubber pad press, 260 MN

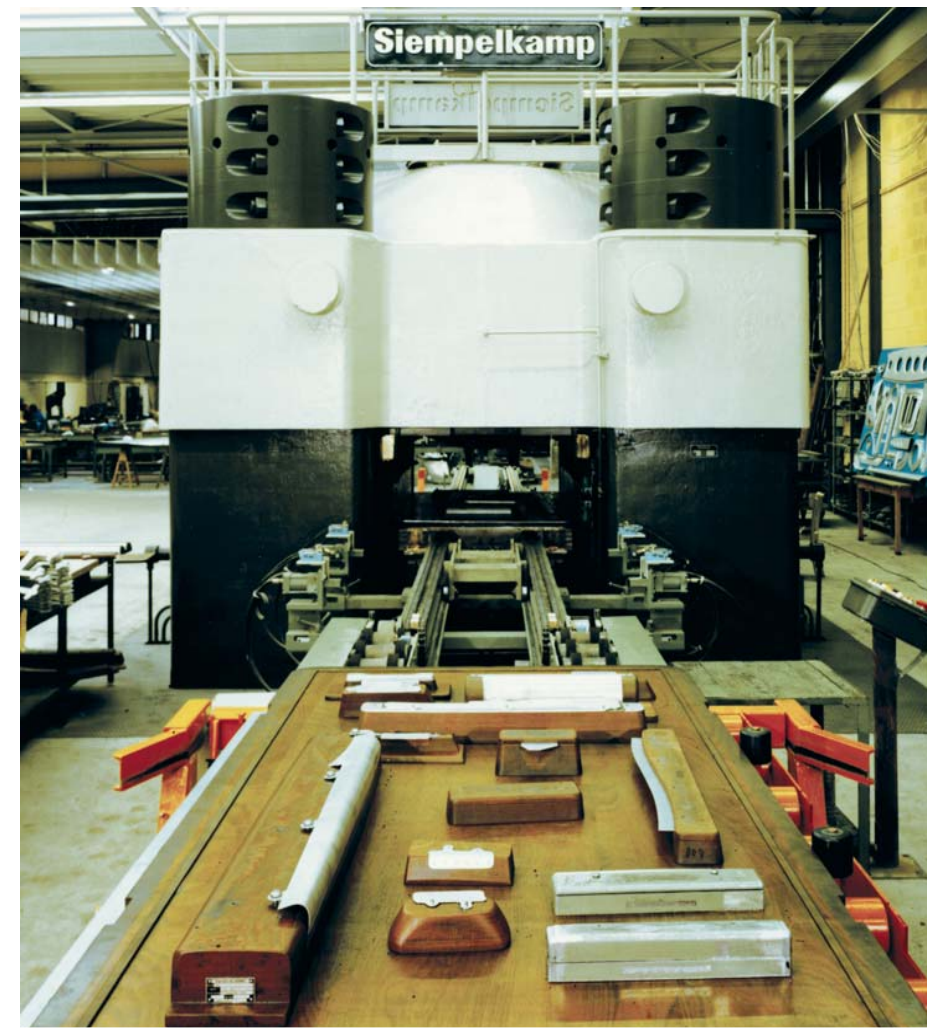

Rubber Pad Press

Solid rubber pad presses (Guerin method) for ultra-high specific forming pressures, suitable for the production of high definition sheet metal components for the aerospace industry and similar applications
 With: • table loading systems or
 • computer-controlled pallet
 • round-about system

3



Hydroforming press, 50 MN

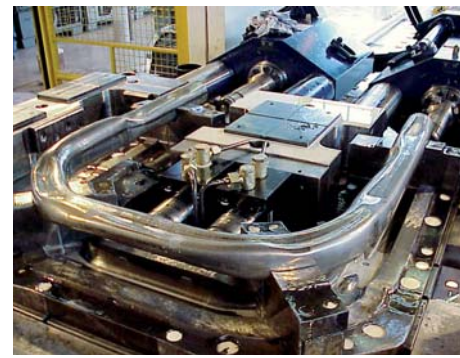

Typical tool for hydroforming

Hydroforming

For the manufacture of shaped parts from pipes and tubes with the internal high-pressure

- With:
- program control
 - integrated robots, handling equipment
 - tool changing systems
 - Siempelkamp high pressure intensifier

Try-out pipe forming press, 40 MN



Pipe Forming Press Lines

For the production of large diameter pipes by the 'C'-, 'U'- and 'O'-method

- With:
- automatic parallelism control independent of the pipe length
 - electronic stroke control
 - integrated transport systems
 - devices for quick tool change



110 MN crimping press



A crimped 50 mm plate

Crimping Press

New design!
Due to the higher pressing force it is now possible to also form highest strength material

720 MN O-forming press



O-Forming Press

The largest press of this type in the world comes from Siempelkamp

6 Complete solutions: design, casting, machining, assembly and commissioning from a single source

As one of the leading global providers of metal forming machinery, we set international standards. We offer our clients a combination of machine construction and process engineering know-how that is unique. This combination of skills enables us to provide our clients with comprehensive solutions that cover the entire spectrum from the design and construction of a machine to its final commissioning.

Construction tailored to your needs

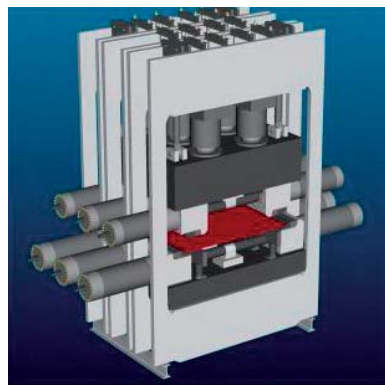

3D animation of a crimping press

Siempelkamp uses these potentials to create client-oriented solutions. The electronic drawing board of CAD programs makes it possible to turn three-dimensional volume models into multi-dimensional drawings and animated visualizations – providing the perspectives necessary for developing client-specific solutions!

FEM calculations create transparency

A long lifespan with very little wear and tear, low-level maintenance and optimal usability: those are the clearly formulated demands set

In engineering, trustworthy traditions are a valuable thing. These traditions constantly benefit from better, more modern and more precise means of production that open up new perspectives in machine manufacturing.

Siempelkamp uses these potentials to create client-oriented solutions.

for our metal forming presses. Our analyses with various FEM systems (e.g. ANSYS and MARC/Mentat) support us in meeting these demands by calculating the entire model of the presses being built. The advantages: the real stresses that occur during operation are shown more precisely, making the design of the individual parts more reliable. Once the stresses are defined, sub-models can be used to analyze individual parts and their interconnections. The stress analysis is carried out according to recognized German and international rules and standards (e.g. FKM Guidelines, IIW recommendations, AD bulletin, VDI2230).

Heavy-weight casts from our own foundry

When it comes to the casting of ultra-heavy special and high-precision parts we are constantly setting new benchmarks – e.g. with our current cast of a 260 t moving crosshead. Using the drawings of our design engineers, our company foundry, with its high level of expertise in manually produced casts, plays a decisive role in the success of our products. Here as well, our range of services is truly comprehensive and offers our clients significant added value.

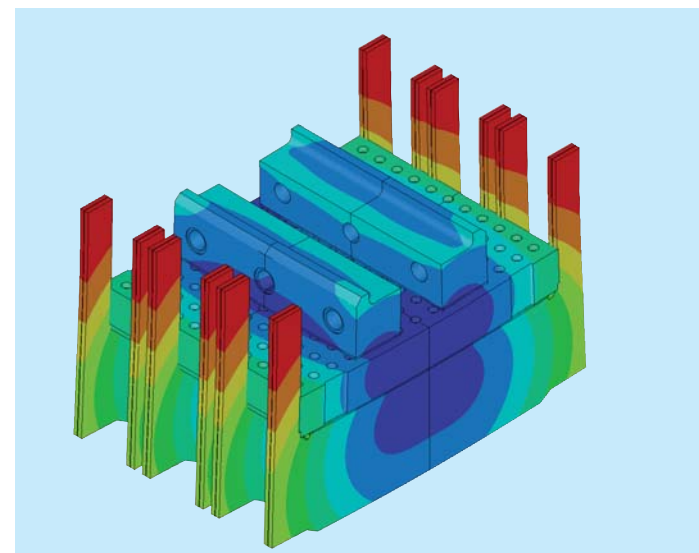

Values calculated by FEM



Casting of a 260 t upper beam



Assembling of the press frames



The press table is installed



The upper beam goes into the press

Finishing

Our quality standards are carried right through the entire production chain and include the finishing phase: the chip removing process for press tables and moving crossheads on one of the largest portal milling machines in Europe is carried out with the highest level of quality and precision. The same is true for our hydraulics testing area: here the hydraulics can be tested even before the machine is put together. Whether frame, crosshead or pressing table, cylinder and hydraulics: everything is built in Krefeld, and our focus is always on precision, including the precision of the software programs we develop.



Welded construction of an upper beam



Portal milling machine machining the upper beam

Assembly

After the planning, manufacture and finishing, the assembly is the final step in delivering a reliable, comprehensive solution. The Siempelkamp teams are there at the client's, ensuring that this last step is carried out with the same expertise and efficiency.

Commissioning

The successful commissioning gives our clients the security that from now on they will be able to count on the reliability of Siempelkamp technology to help them supply their markets with the goods they produce. For us, the commissioning is an important link in the chain of our production processes – and the insurance that we have delivered an optimal product to our clients. As such, our commissioning is not just an important part of our production chain, but also a valuable milestone in our relationship to our clients.



Ready for commissioning

Metal Forming Presses: Complete Solutions

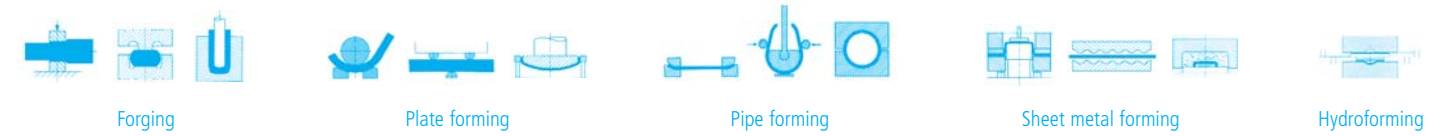

8



Hydraulic components in the workshop



Hydraulic room

Hydraulics

In addition to mechanics, Siempelkamp's process know-how also includes the important area of hydraulics. Our dedicated hydraulics department is made up of around 80 employees who design and manufacture the highly specialized hydraulic power units required specifically for pressing. Quality control is carried out in our own testing facilities where the functionality of our hydraulics is tested so that only absolutely flawless units are delivered to the construction site. In addition, we always try to ensure the highest possible degree of prefabrication, for example for such things as the hydraulic piping. Parts that are not produced by Siempelkamp are always sourced from renowned manufacturers such as Rexroth, Oil Gear Towler, Hydac, etc. These manufacturers have service centers around the world and can provide you with spare parts no matter where you are located. Everything we do aims at achieving short commissioning and ramp-up times.

Electric units

The third column of our comprehensive solutions for the manufacture of metal forming presses is Siempelkamp's own electric control systems and our process control engineering.

Here as well, we have specialists that design and produce systems specifically for your needs. There is also a separate team specifically for the switchgear cabinet. The electric components are parameterized in advance and then tested together with the hydraulics. Electronic components are produced by such renowned manufacturers as Siemens, Allen Bradley, etc. All operations are united in one control system and are accessible through a unified operator interface, enabling the machine operator to quickly learn how to use the new controls and ensuring a safe handling of the press. Siempelkamp metal forming presses have a very high degree of automation. For example, we offer "computer-aided forging" for open-die forging presses. When tool numbers are entered, the machine calls up 'pass schedules' and then forges the required piece automatically. Process control technology is also made by Siempelkamp. With the Prod IQ system, Siempelkamp offers an integrated process control technology that registers all of the relevant parameters from the completely networked parts of the machine. This information is

9



High rack stacker with fully automatic shelf stacker

registered in layer, commission and stand still production logs, which then form the basis for a more economical production. The goal here is to attain a high degree of process stability and a maximum machine utilization rate.

Handling and storage

Through two specialized subsidiaries, Siempelkamp is also able to offer comprehensive solutions for product handling as part of the pressing process. Siempelkamp Handling Systems are the specialists for automation in the area of roller conveyors and suction vehicles for separation and stacking. With its linear robots, Strothmann stands for flexibility and productivity. A high level of dynamism while handling large weights and the optimal use of space are the characteristics that define products such as blank loaders, blank coating systems, centering stations and orienting stations. Siempelkamp Handling Systems can also offer its customers the advantages of having a storage system integrated into the production environment. The basis for the system is a steel high-bay storage system with fully automated storage and retrieval. The efficient storage administration

system makes every product available at any time. The advantages are the excellent use of space, safe and material-friendly transport and an optimal tie-in to the production system which results in greater flexibility and a higher degree of availability.

Complete production lines

With its all-encompassing know-how, Siempelkamp is able to design and deliver entire pressing units and production lines. We develop, manufacture and commission machining concepts for your entire production process. Our focus is always on the greatest possible customer benefit and how to produce that benefit economically.

Service

All Siempelkamp systems offered on the market come complete with life-time service. So, despite their legendary reliability, you are covered in case the unexpected does happen: Our internet service helps to quickly deal with the initial fault analysis. Service points around the globe can offer fast and efficient help with spare parts and manpower to get the repair done. That gives the operators of our machines the security of having a strong partner at their side who has been building and looking after presses for 125 years.



Switch cabinet manufacturing



Computer-aided forging

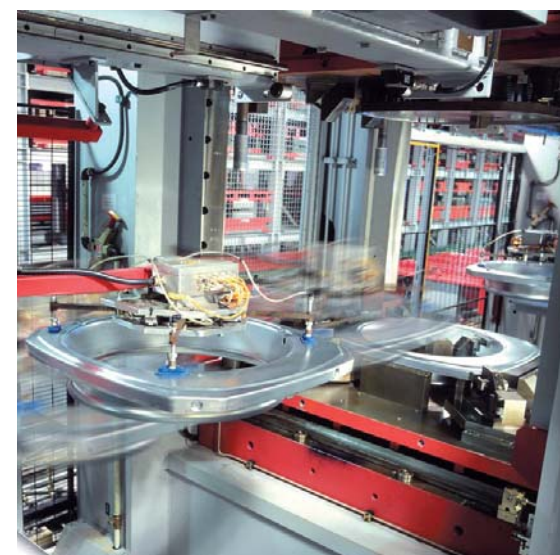

Line feeder in motion

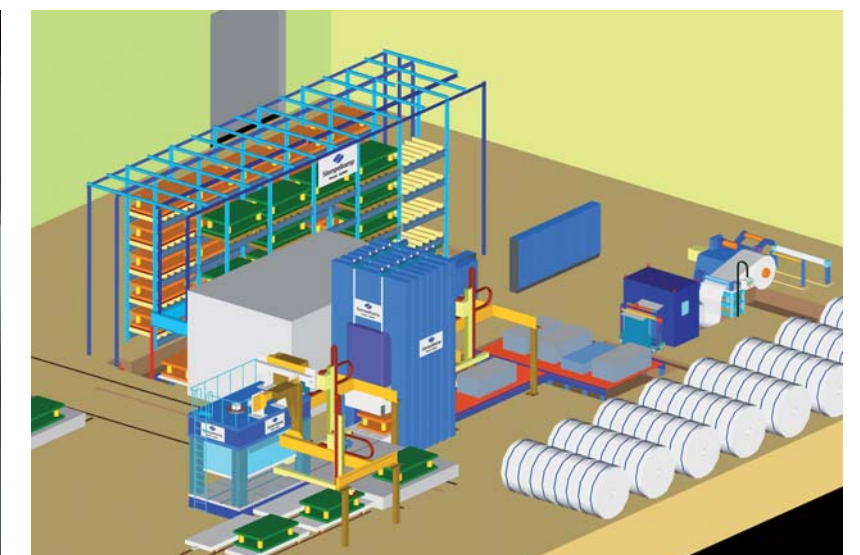

Complete production line

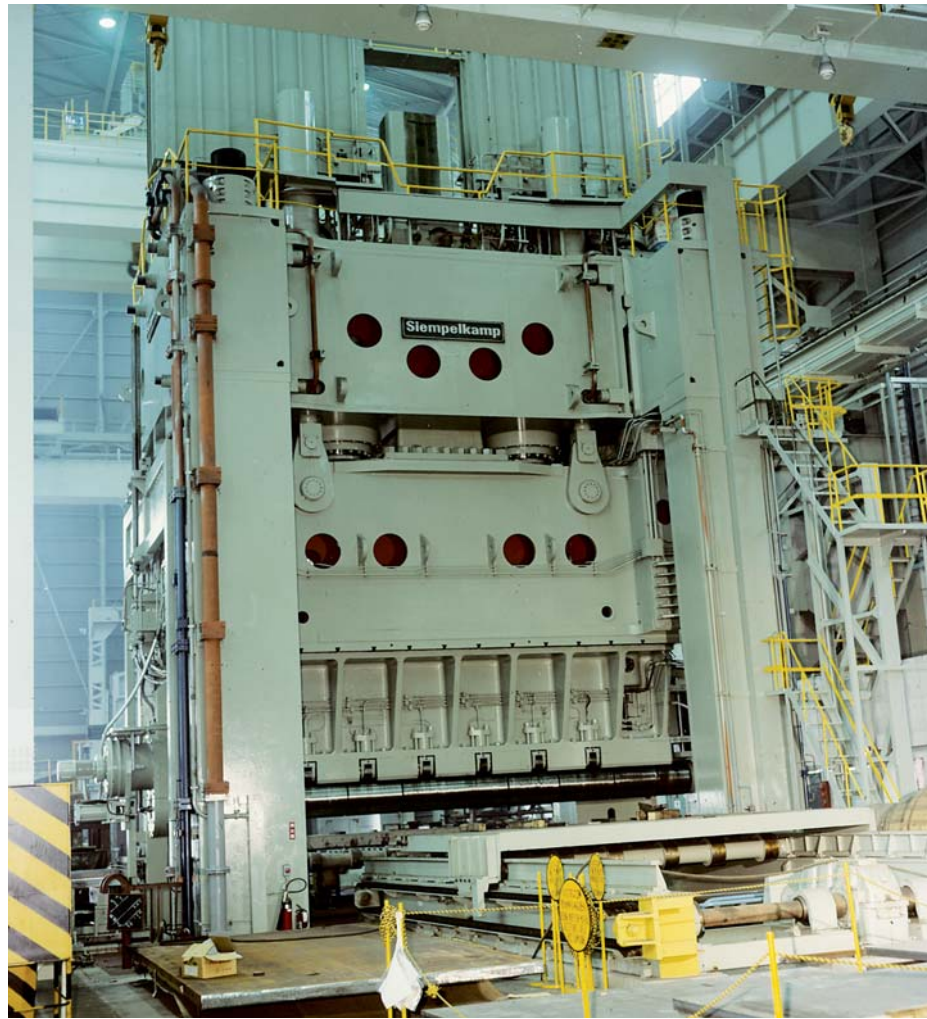
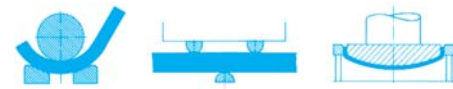
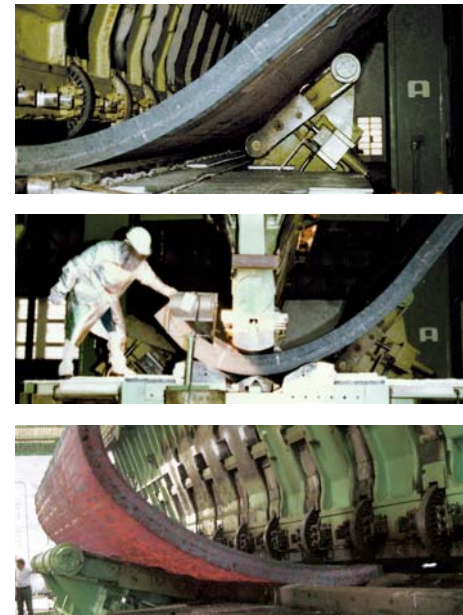

Plate bending and dishing press, 100 MN

Straightening press for heavy plates



Forming of a half shell

Plate Bending Press

For hot and cold forming of half shells, spherical segments of various shapes for large container and tank construction

- With:
- special bending tool
 - workpiece manipulators
 - shifting table
 - tool changing devices

Straightening Press

For heavy plates, slabs, bars, tubes, shafts, etc.

- lateral cylinder shifting arrangement
- workpiece transport
- measuring devices
- workpiece manipulators
- electronic control of straightening stroke

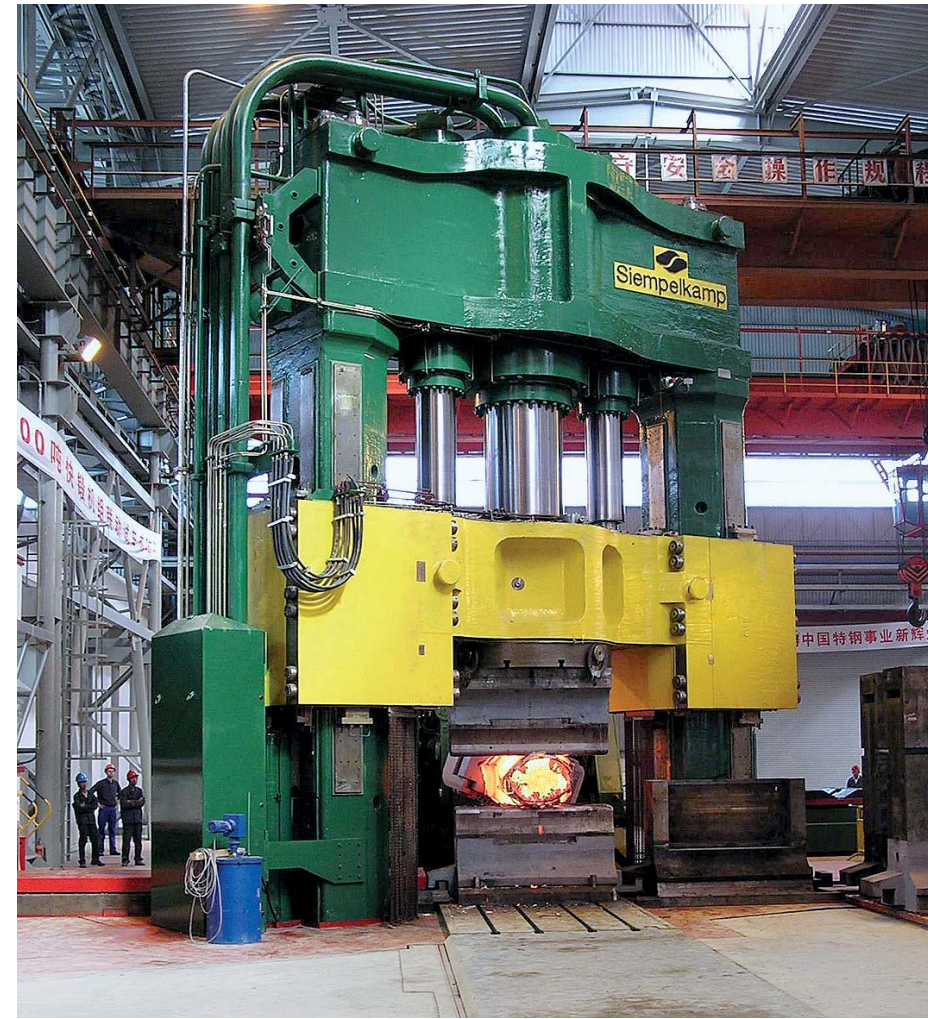
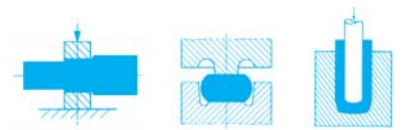

Open-die forging press, 40/45 MN with manipulator

39 MN open-die forging press



View into the working area

Open-Die Forging Press

In two-column frame design, push-down or pull-down version; for the forging of bars, rings, discs, preforms, pierced blanks, etc.

- With:
- integrated manipulators
 - die clamping and turning device
 - die cross shifting unit
 - die magazine
 - table shifting

Forging process supported by:

- computer-aided forging program
- state-of-the-art visualization

Efficiency of production increased by:

- shortest die-changing cycles
- highest possible forging speed and frequency due to a shock-free smooth hydraulic control system:
 - 120 strokes/min. while planishing
 - 40 strokes/min. while cogging

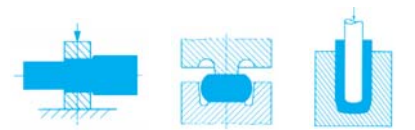

16 MN original clutch-controlled screw press

Typical parts

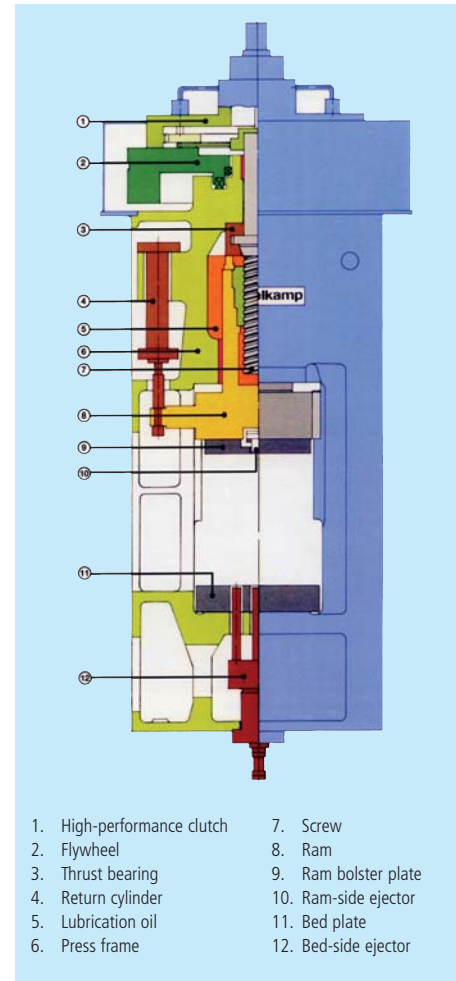

Clutch-Controlled Screw Press

Stroke-independent press for economic manufacturing of conventional die forgings or precision forgings by upsetting, extruding, calibrating, coining, trimming, etc.

- With:
- great forming energy per working stroke
 - full pressing force at any ram position
 - variable stroke limitation
 - shortest hot contact time
 - optimal ram guiding

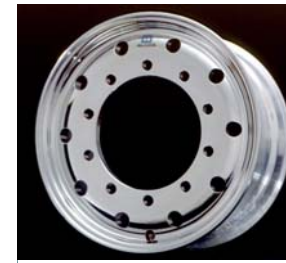

A forged rim for trucks



Wheel forging line, 80/50/30 MN including die-changing devices

Bottle forging line consisting of upset and pierce press, 22.5 MN; ironing press, 3.4 MN



Gas bottles

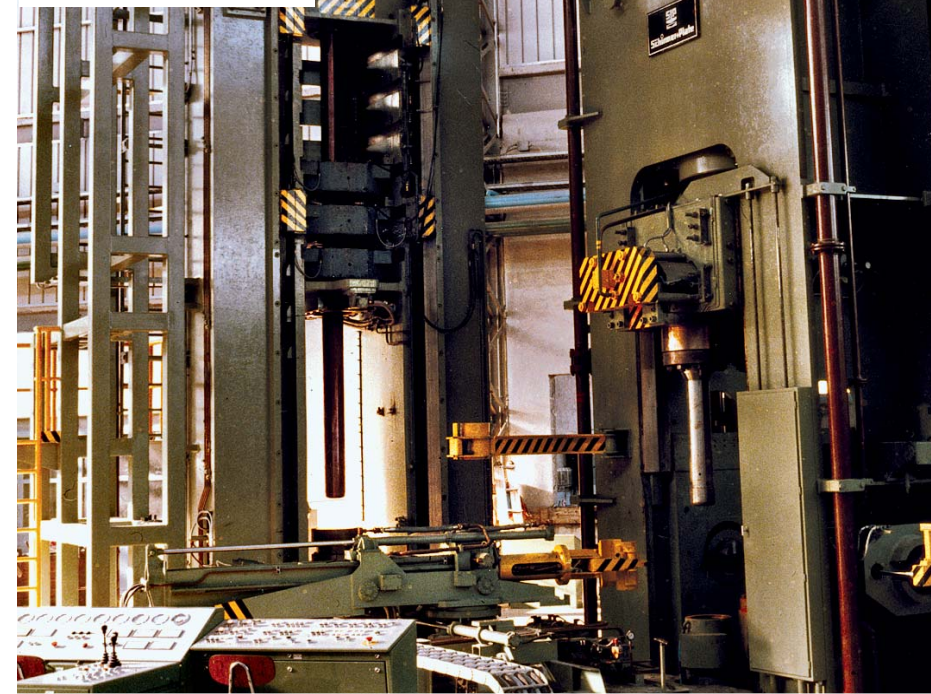

Closed-Die Forging Press

For high-tech forged parts with extreme contour accuracy

- With:
- four-point parallelism control
 - exactly adjustable forming speed
 - tool heating systems
 - connecting equipment for vacuum and inert gas systems manipulators

For the production of cylindrical parts, gas bottles, pressure vessels, pierced blanks, etc. by the upsetting, piercing and ironing method

- With:
- program control
 - fully automatic workpiece handling equipment
 - quick tool changing systems
 - tool lubricating and cooling systems



400 MN closed-die forging press

Closed-Die Forging Press for Aircraft Parts

For high-tech forged parts with extreme contour accuracy

- With:
- program control
 - fully automatic workpiece handling equipment
 - quick tool changing systems
 - tool lubricating and cooling systems

Parts of nickel-based alloys



Wire-wound press frame. Press force 200,000 kN

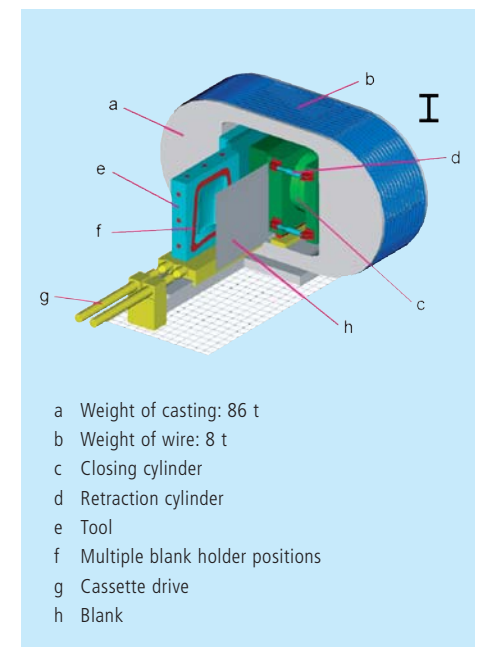

Wire-wound hydroforming press, computer simulation

- a Weight of casting: 86 t
- b Weight of wire: 8 t
- c Closing cylinder
- d Retraction cylinder
- e Tool
- f Multiple blank holder positions
- g Cassette drive
- h Blank

Areas of application

The wire-winding technology is mainly used on metal components in press construction and in pressure vessel manufacturing. These areas of mechanical engineering require the control of very high internal pressures with resulting high press forces. In addition, the goal is to achieve an optimized design by minimizing the dimensions and the weight of the body. A solution to this problem is the use of the wire-winding technology as shown in the example of a hydroforming press.

Under compression the fatigue strength of cast iron is much higher than under tension, up to twice as much. The combination of casting design and wire-winding creates a harmonic stress field, avoiding stress concentrations while reducing the weight of the machine.

Pre-stressed wire-wound frames manufactured by the Siempelkamp foundry have been successfully used in various metal forming applications.

Press frame for a hydroforming press. Press force 100,000 kN

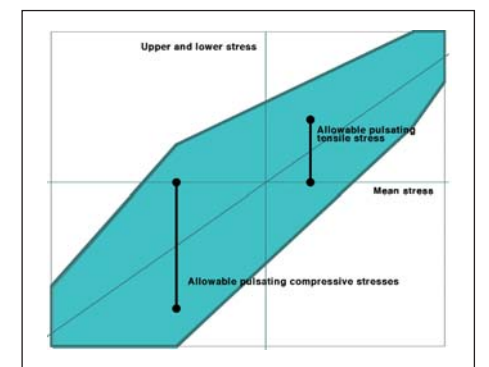
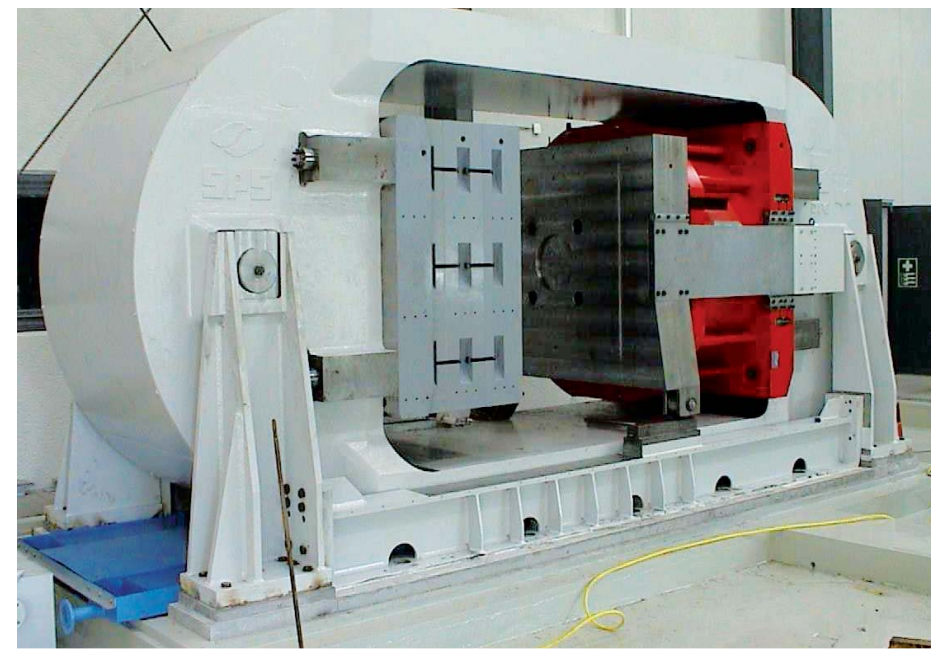

Smith diagram for ductile cast iron GJS-400



Siempelkamp Maschinen- und Anlagenbau GmbH & Co. KG



Siempelkamp (Wuxi) Machinery Manufacturing Co. Ltd., China



ATR Industrie-Elektronik GmbH



Siempelkamp Handling Systeme GmbH



Siempelkamp CZ s. r. o.



Machines & Handling
W. Strothmann GmbH



Siempelkamp Energy Systems GmbH



Büttner Gesellschaft für Trocknungs- und Umwelttechnik mbH



CMC S.r.l.



Siempelkamp Logistics & Service GmbH



Sicoplan N.V.



Hombak Maschinen- und Anlagenbau GmbH

Sales companies/Representatives

Australia

Siempelkamp Pty Ltd.

Brazil

Siempelkamp do Brasil Ltda.

China

Siempelkamp (Wuxi) Machinery Manufacturing Ltd., Beijing

France

Siempelkamp France Sarl

India

Siempelkamp India Pvt. Ltd.

Russia

Siempelkamp Moscow

Singapore

Siempelkamp Pte Ltd.

Spain

Siempelkamp Barcelona

Turkey

Siempelkamp Istanbul

USA

Siempelkamp L.P.